

VQ Series Vane Pumps

—High Performance Intravane Pumps For Mobile Applications

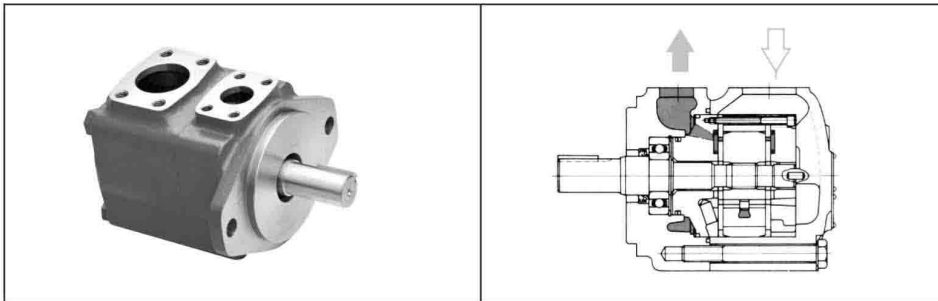

VQ Series Single Pumps



Model Code

(F3-)	25VQ	21	A	(F)	-1	A	20	L
Prefix	Series	▲ Code	Port Connections	Mounting	Shafts	Outlet Position	Design	Rotation
Omit-Using antiwear oil water glycol fluid	20VQ	2,3,4,5,6,7,8,9, 10,11,12,14	A-SAE 4-bolt flange	Omit-Flange mounting	1-Str.key 151-Spline	(Viewed from cover end of pump)	30	(View from shaft end of pump)
	25VQ	10,12,14,15,17, 19,21			1-Str.key			
F3-Phosphate ester fluid	35VQ	21,25,30,32,35, 38,45		F-Foot mounting	86-HD str.key	A-Opposite inlet port B-90° CCW from inlet C-Inline with inlet D-90° CW from inlet	20	
	45VQ	42,45,50,57,60, 66,75			11-Spline			

▲ Rated capacity (US gpm) at 1200 r/min and 0.7 MPa (100psi).

Specification

Model	Code	Displ mL/r	Max. Speed r/min	Max. Pressure MPa	Typical del. L/min ▲ max. speed & pressure	Typical input kW ▲ max. speed & pressure	Weight kg
20VQ	2	7	2700	21	16.4	7.2	11.8
	3	11.7	2700	21	24.4	10.8	
	4	15	2700	21	32.7	14.4	
	5	18	2700	21	42.3	17.9	
	6	19	2700	21	50.6	21.5	
	7	22	2700	21	58.8	23.7	
	8	27	2700	21	56.4	25.1	
	9	30	2700	21	73.4	26.0	
	10	31.5	2700	21	81.7	26.8	
	11	36	2700	21	88.5	27.7	
	12	40	2700	16	96.5	28.4	
	14	45	2700	14	115.4	29.1	
	25VQ	10	32.5	2700	21	81.4	
12		38.3	2700	21	88.5	41.0	
14		43.3	2700	21	103.8	46.6	
15		47.3	2500	21	109.4	48.1	
17		52.5	2500	21	119.2	51.8	
19		60	2500	21	133.5	55.2	
35VQ	21	65.0	2500	21	146.2	61.9	22.7
	21	64.0	2500	21	145.5	63.7	
	25	79.2	2500	21	173.1	75.3	
	30	95.0	2500	21	211.5	87.7	
	32	101	2500	21	220.2	92.2	
	35	109	2400	21	230.8	98.5	
45VQ	38	118	2400	21	250	104.4	34.1
	45	140	2400	21	271.2	99.8	
	42	134	2400	17.5	255.8	91.4	
	45	147	2200	17.5	271.2	99.8	
	50	156	2200	17.5	303.8	105.2	
	57	180	2200	17.5	343.7	120.2	
	60	189	2200	17.5	369.2	126.8	
66	208	2200	17.5	408.7	142.4		
75	237	2200	14	460	120.2		

Performance constants:SAE 10W fluid ▲82°C(180°F), and pump inlet ▲0 PSIG(14.7PSIA)

Note:Outlet pressure must always be higher than inlet pressure.

20VQ Series flow, input power type

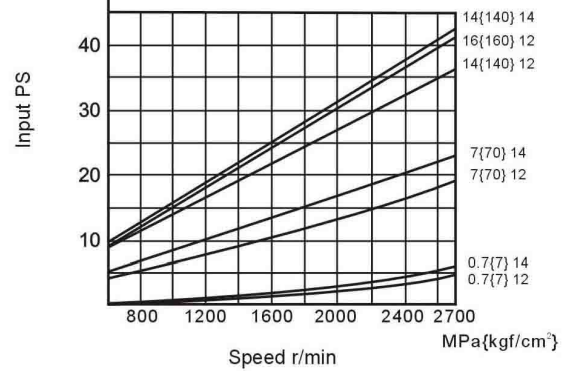
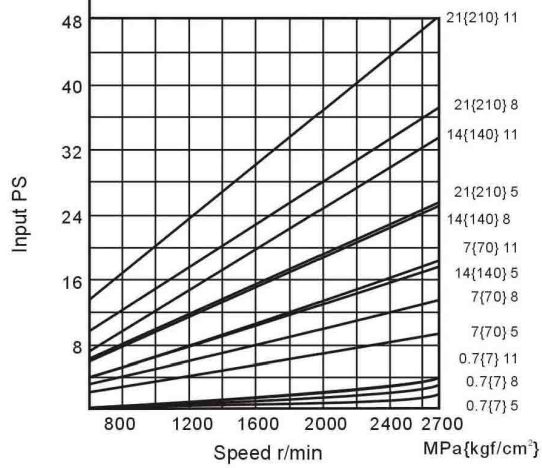
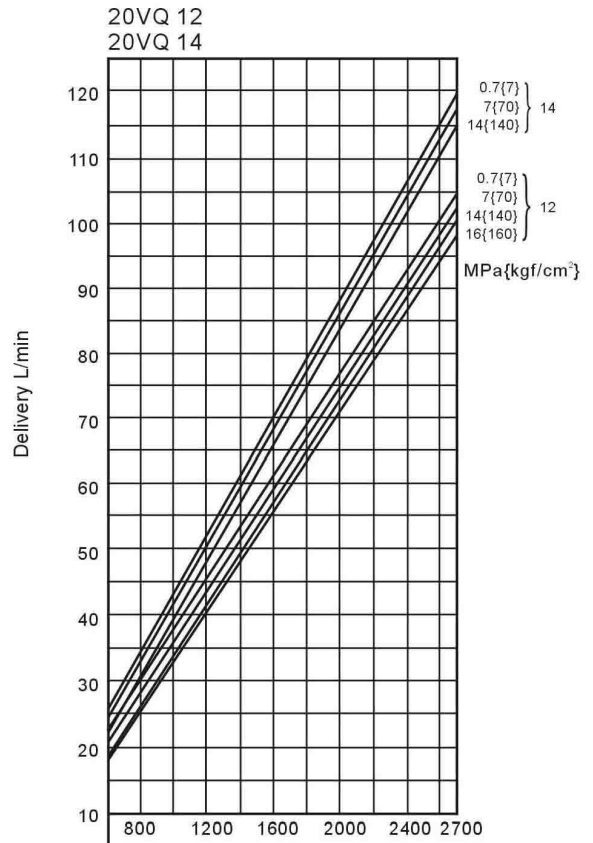
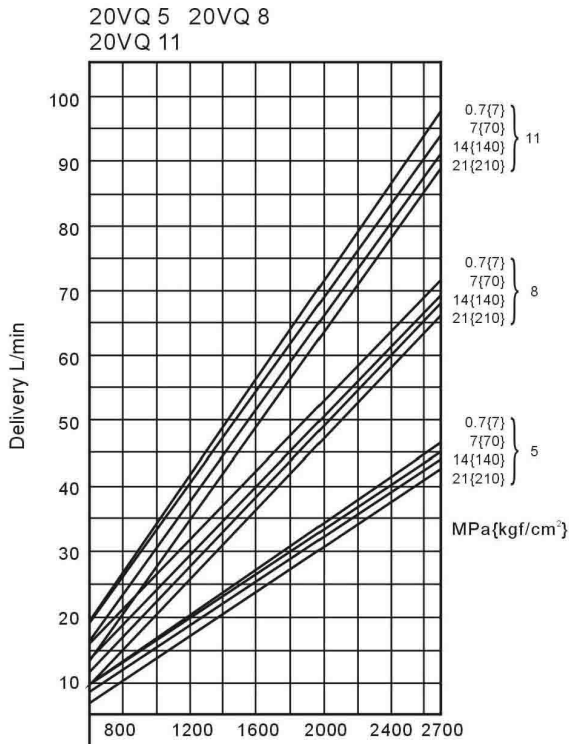

25VQ Series flow, input power type

25VQ 12 25VQ 17

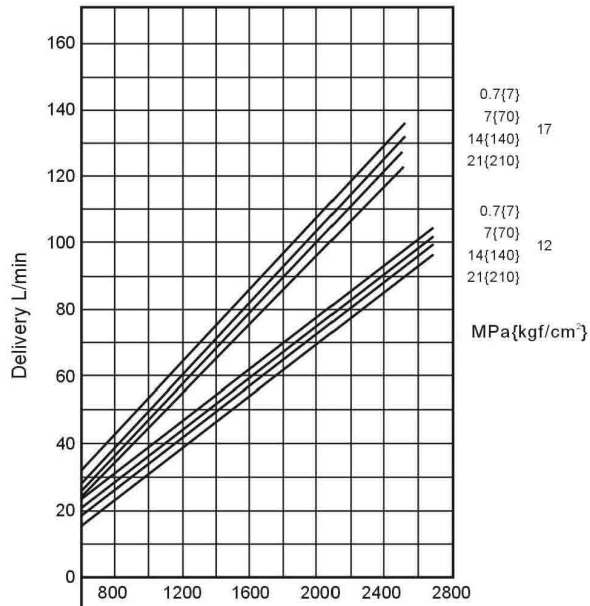

25VQ 14 25VQ 21

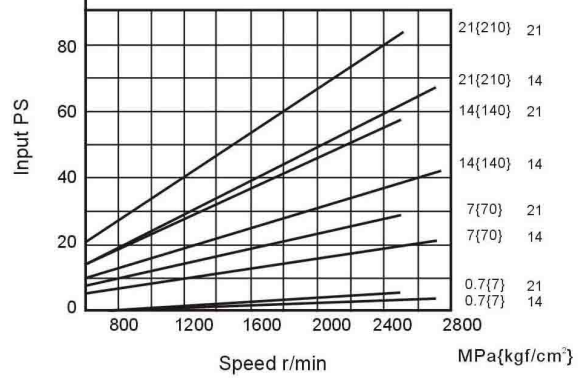
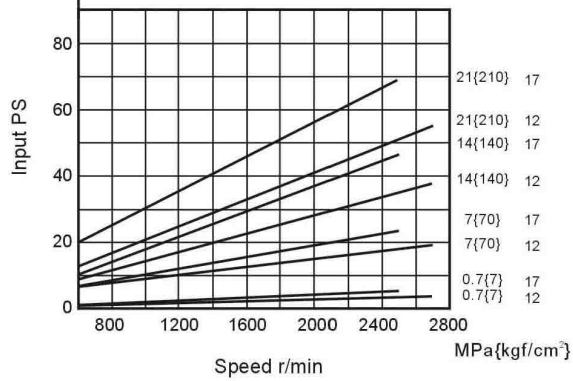
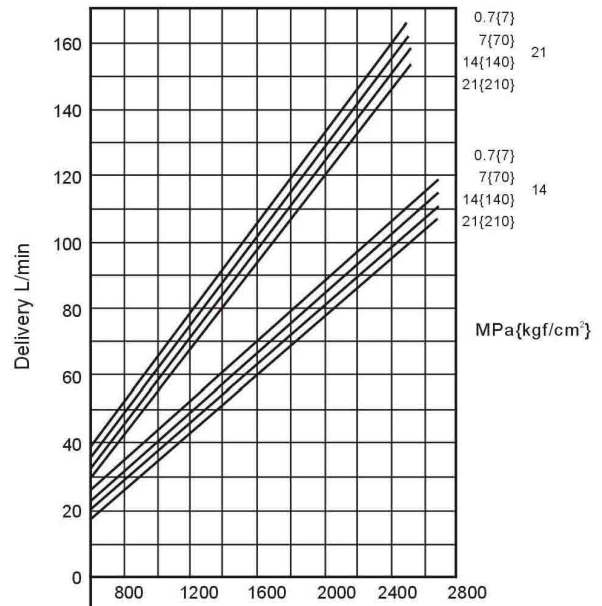

45VQ series flow input power type

45VQ 42 45VQ60

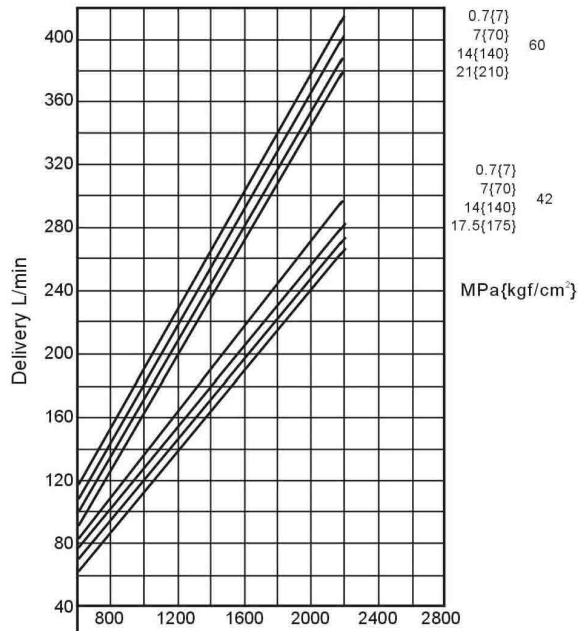

45VQ 50

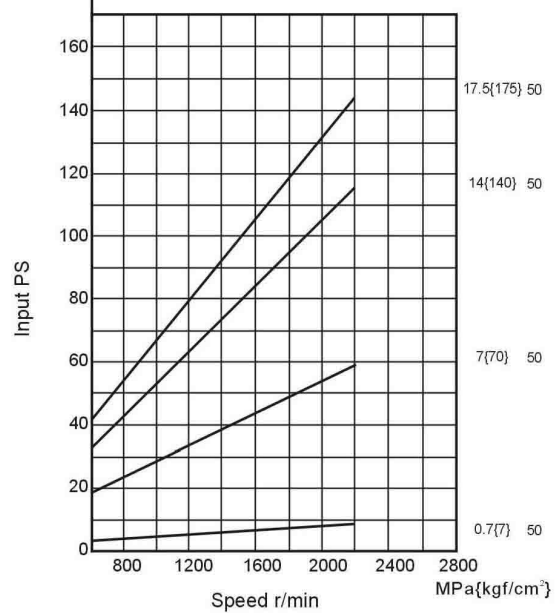
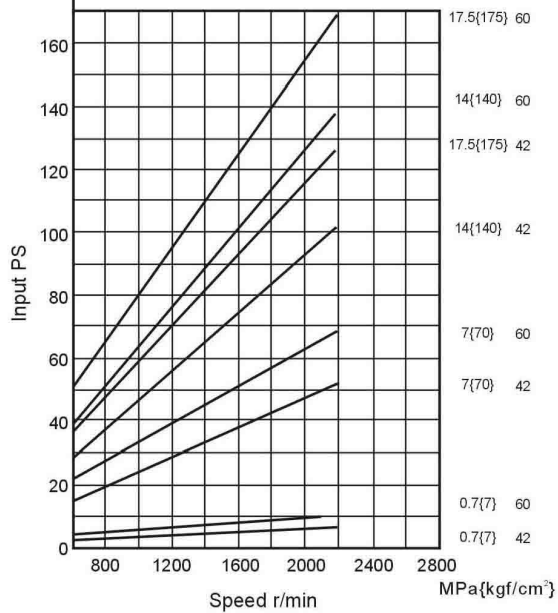
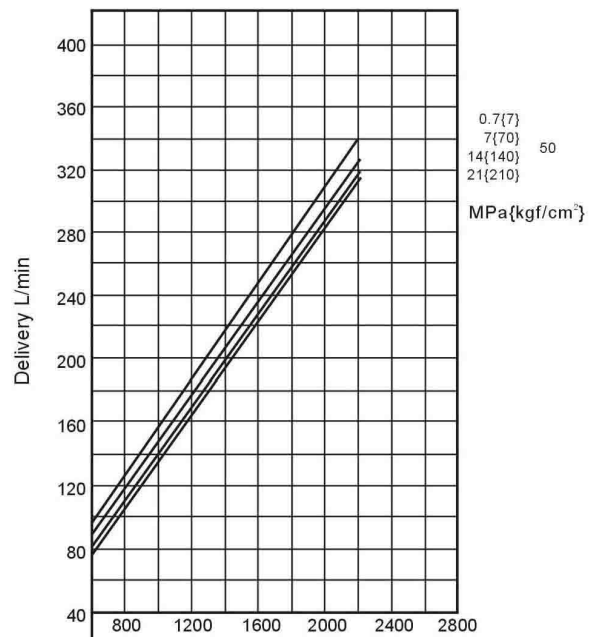

35VQ series flow input power type

35VQ 25 35VQ35

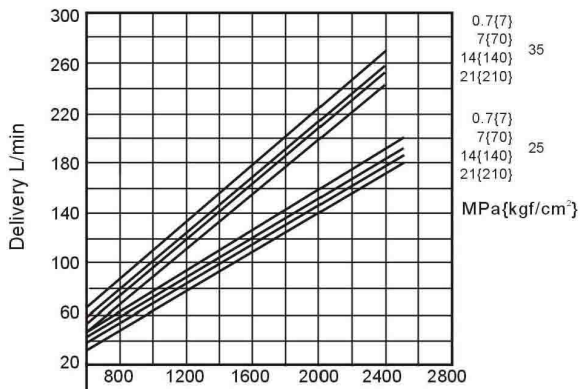

35VQ 30 35VQ38

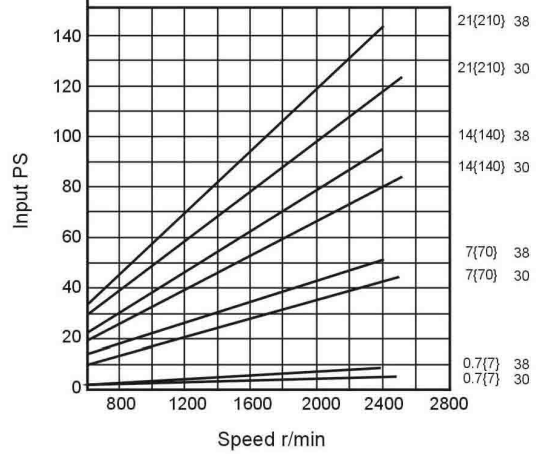
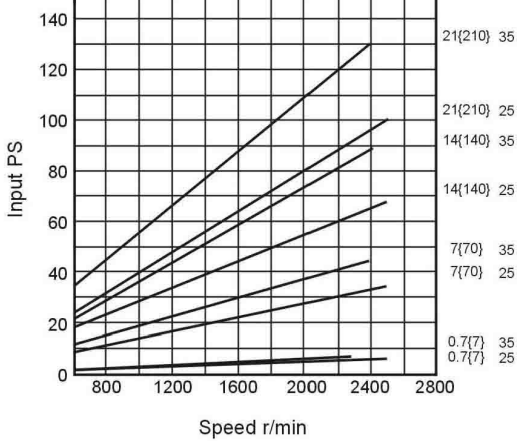
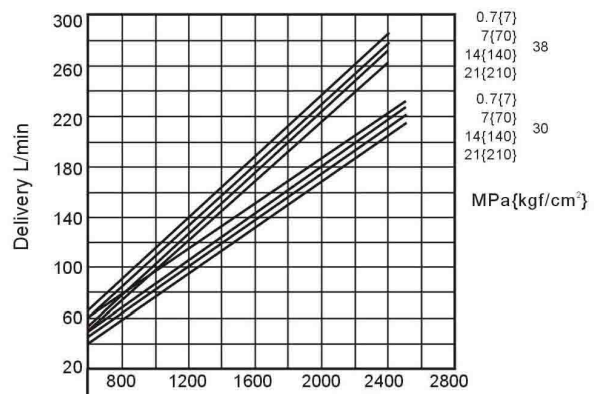

Installation dimensions

20VQ Flange Mounting

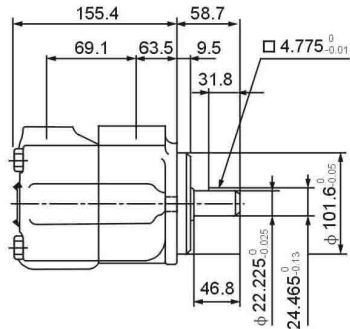
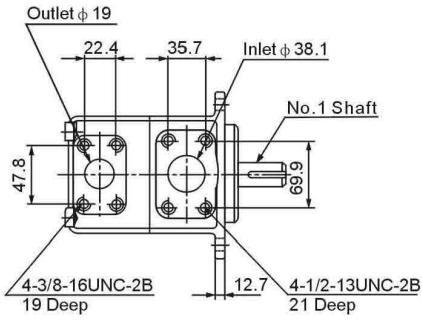

20VQ Foot Mounting

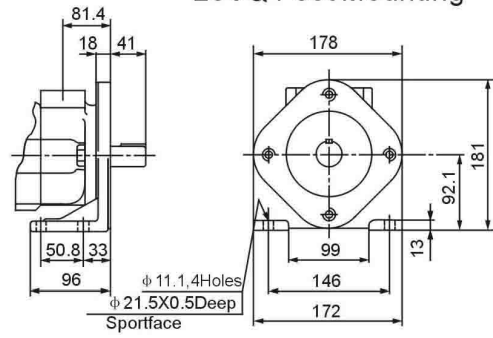

For other dimensions, refer to "Flange Mounting" type.

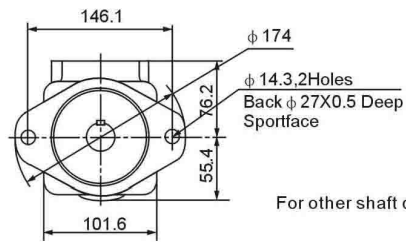

For other shaft dimensions, refer to page 49

25VQ Flange Mounting

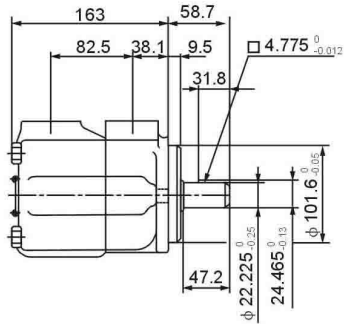
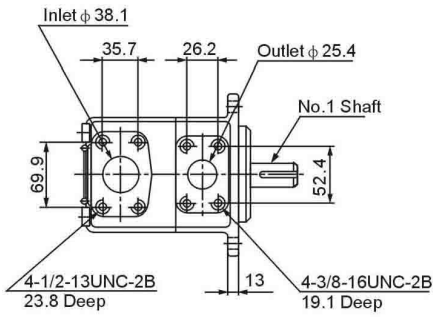

25VQ Foot Mounting

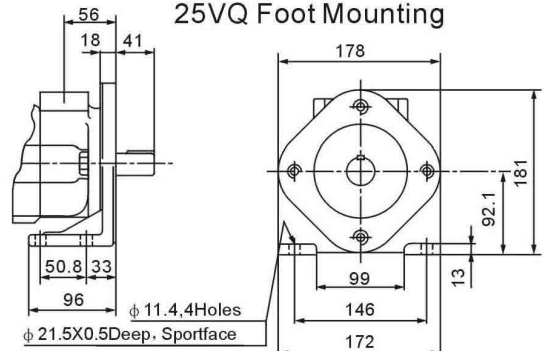

For other dimensions, refer to "Flange Mounting" type.

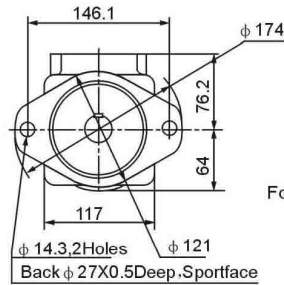

For other shaft dimensions, refer to page 49

Installation dimensions

35VQ Flange Mounting

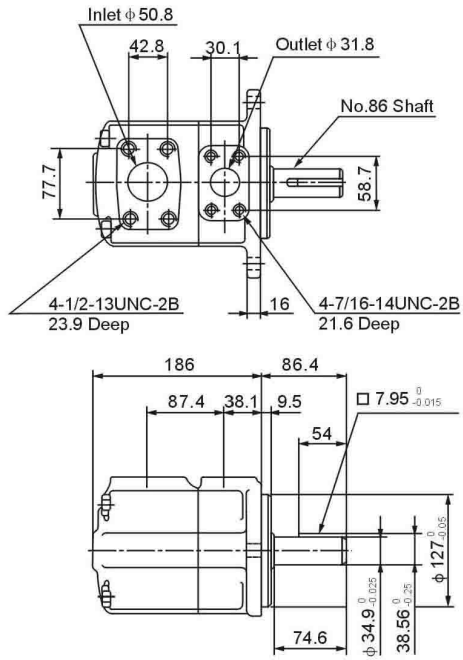

35VQ Foot Mounting

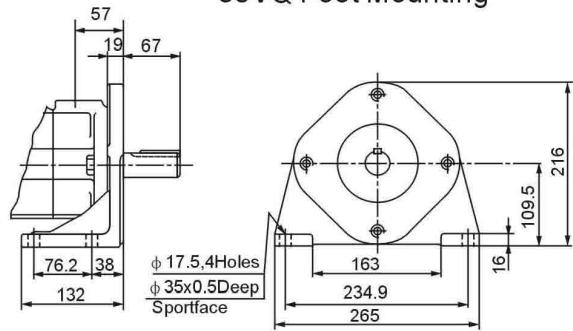

For other dimensions, refer to "Flange Mounting" type.

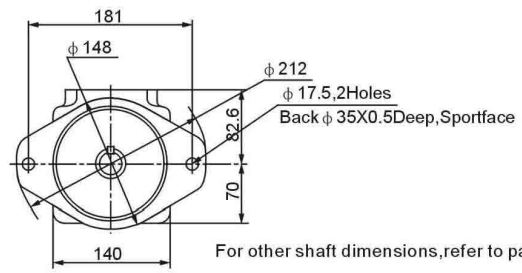

For other shaft dimensions, refer to page 49

45VQ Flange Mounting

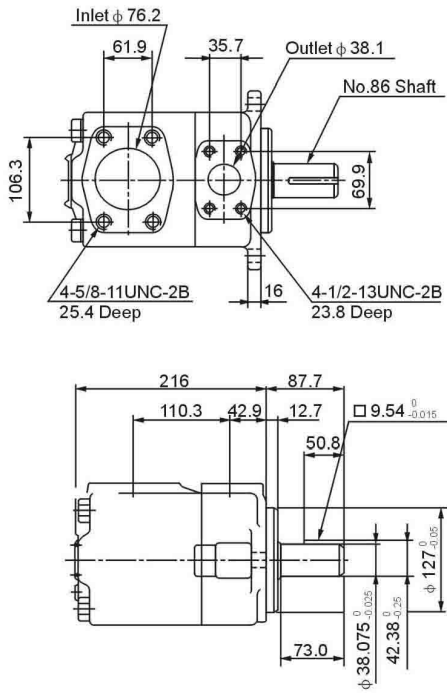

45VQ Foot Mounting

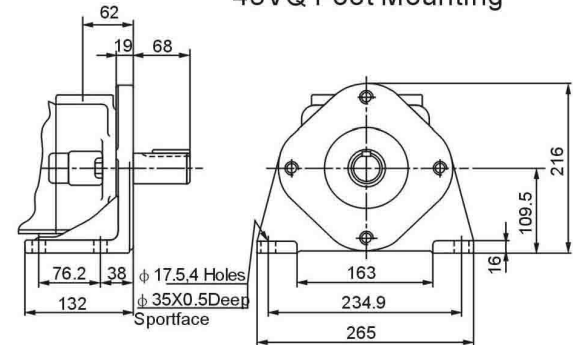

For other dimensions, refer to "Flange Mounting" type.

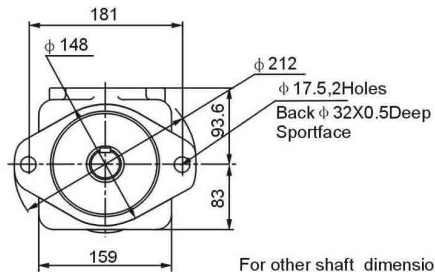

For other shaft dimensions, refer to page 49

VQSeries Double Pumps

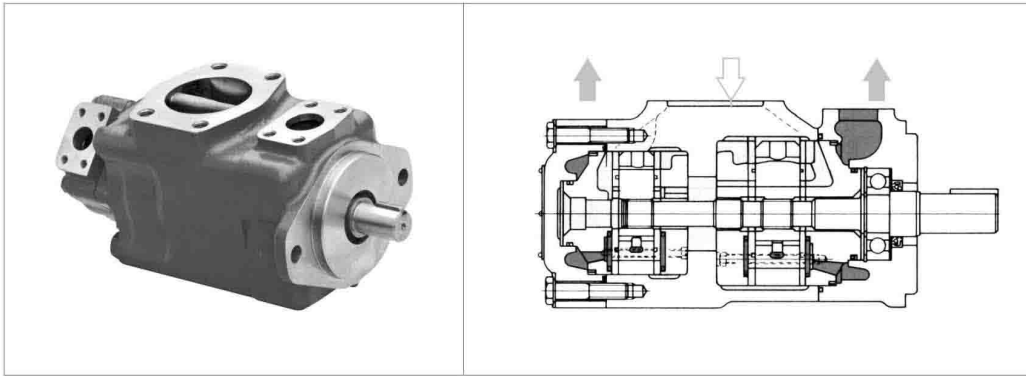

Model Code

(F3-)	****VQ	**	A	**	(F)	-*	*	20	*			
Prefix	Series	▲ Code Shaft End Pump	Port Connections	▲ Code Cover End Pump	Mounting	Shaft	Port Connections	Design	Rotation			
Omit-Using antiwear oil water glycol fluid	2520VQ	10,12,14,15,17,19,21	A-SAE 4-bolt flange	2,3,4,5,6,7,8,9,10,11,12,14	Omit-Flange mounting	1-Str.key	See below	20	(Viewed from shaft end of pump) Omit- Right hand for clockwise L-Left hand for counter clockwise			
	3525VQ	21,25,30,32,35,38,45		10,12,14,15,17,19,21		86-HD Str.key						
	4525VQ	42,45,50,57,60,66,75		10,12,14,15,17,19,21		11-Spline						
F3-Phosphate ester fluid	3520VQ	21,25,30,32,35,38,45		2,3,4,5,6,7,8,9,10,11,12,14	F-Foot mounting	11-Spline				See below	20	(Viewed from shaft end of pump) Omit- Right hand for clockwise L-Left hand for counter clockwise
	4520VQ	42,45,50,57,60,66,75		2,3,4,5,6,7,8,9,10,11,12,14								
	4535VQ	42,45,50,57,60,66,75		21,25,30,32,35,38,45								

▲ Rate capacity(USgpm) at 1200rpm,0.69MPa(100 psi).
Note:For options other than listed in the model code ,i.e,shaft,ports,displacements and mounting,contact us.

Port Orientation Table (Viewed from cover end of pump)

Port Orientation	All series (except 4535VQ)	Series 4535VQ
With No.1 outlet	AA No,2 outlet 135° CCW from inlet	No.2 outlet opposite inlet
	AB No,2 outlet 45° CCW from inlet	No.2 outlet 90° CCW from inlet
Opposite inlet:	AC No,2 outlet 45° CW from inlet	No.2 outlet in line with inlet
	AD No,2 outlet 135° CW from inlet	No.2 outlet 90° CW from inlet
With No.1 outlet 90° CCW from inlet:	BA No,2 outlet 135° CCW from inlet	No.2 outlet opposite inlet
	BB No,2 outlet 45° CCW from inlet	No.2 outlet 90° CCW from inlet
	BC No,2 outlet 45° CW from inlet	No.2 outlet in line with inlet
	BD No,2 outlet 135° CW from inlet	No.2 outlet 90° CW from inlet
With No.1 outlet inline with inlet	CA No,2 outlet 135° CCW from inlet	No.2 outlet opposite inlet
	CB No,2 outlet 45° CCW from inlet	No.2 outlet 90° CCW from inlet
	CC No,2 outlet 45° CW from inlet	No.2 outlet in line inlet
	CD No,2 outlet 135° CW from inlet	No.2 outlet 90° CW from inlet
With No.1 outlet 90° CW inlet:	DA No,2 outlet 135° CCW from inlet	No.2 outlet opposite inlet
	DB No,2 outlet 45° CCW from inlet	No.2 outlet 90° CCW from inlet
	DC No,2 outlet 45° CW from inlet	No.2 outlet in line with inlet
	DD No,2 outlet 135° CW from inlet	No.2 outlet 90° CW from inlet

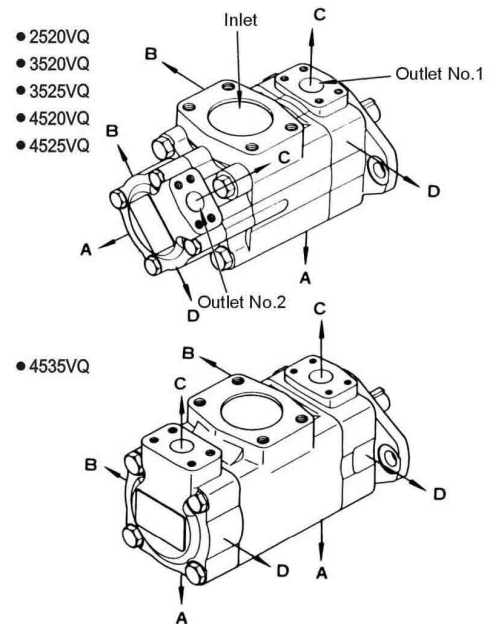

Installation dimensions

2520VQ Flange Mounting

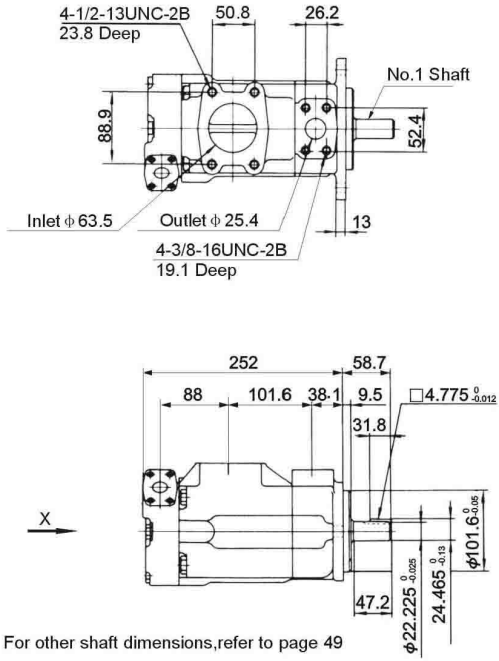

2520VQ Foot Mounting

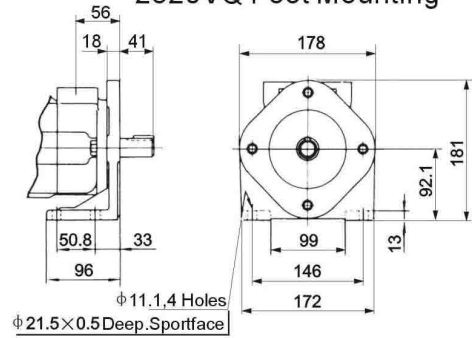

For other dimensions, refer to "Flange Mounting" type.

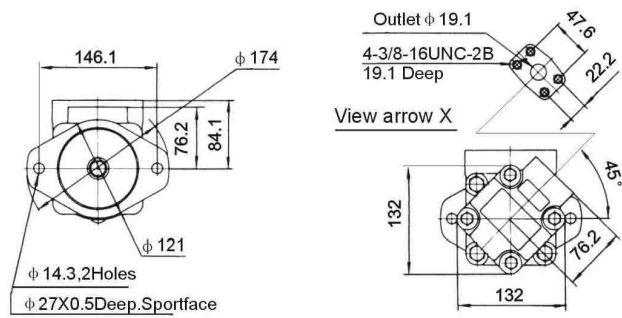

3520VQ Flange Mounting

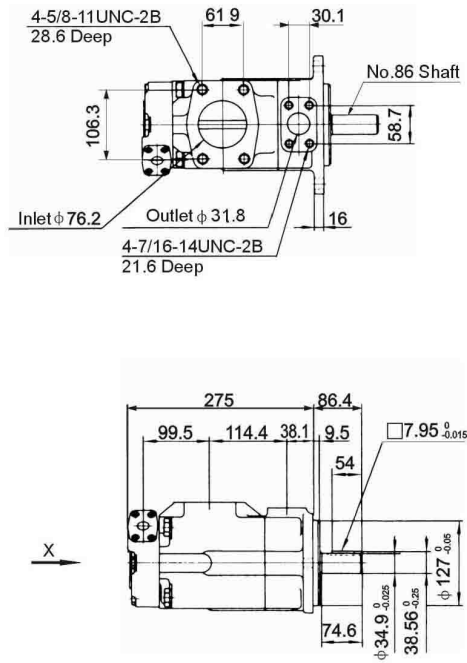

3520VQ Foot Mounting

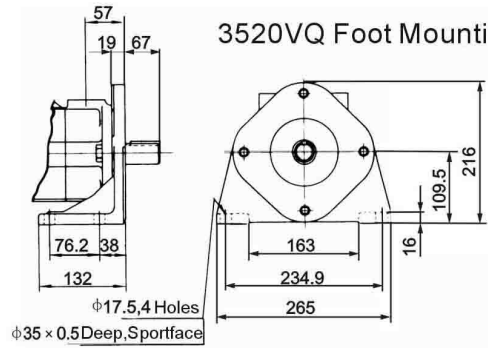

For other dimensions, refer to "Flange Mounting" type.

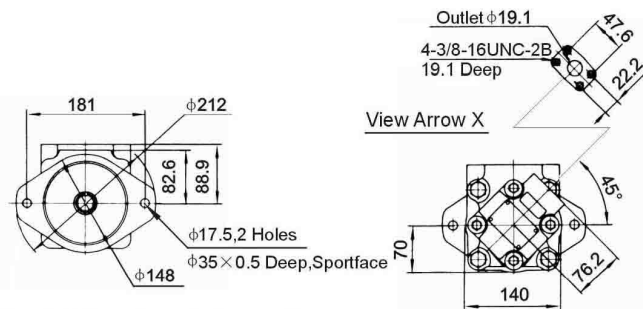

Installation dimensions

3525VQ Flange Mounting

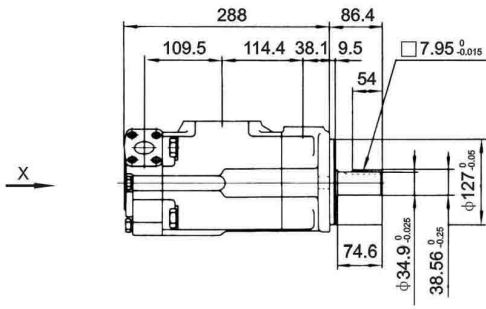
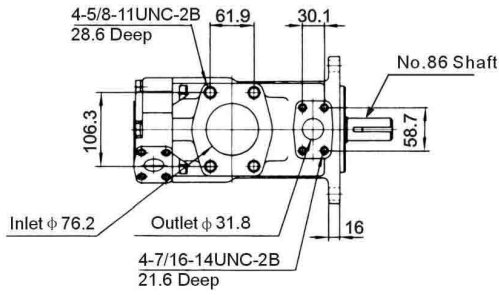

3525VQ Foot Mounting

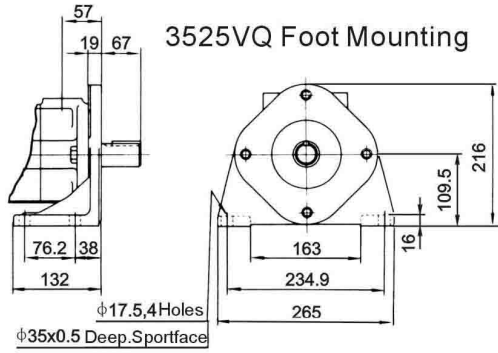

For other dimensions, refer to "Flange Mounting" type.

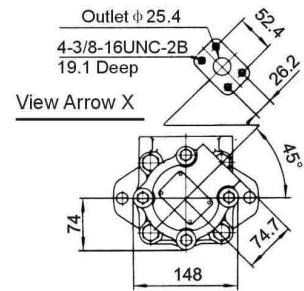
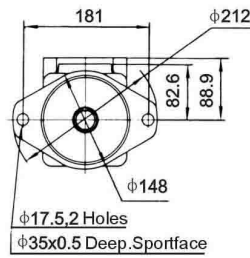

For other shaft dimensions, refer to page 49

4520VQ Flange Mounting

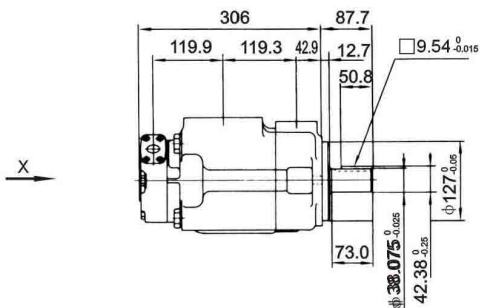
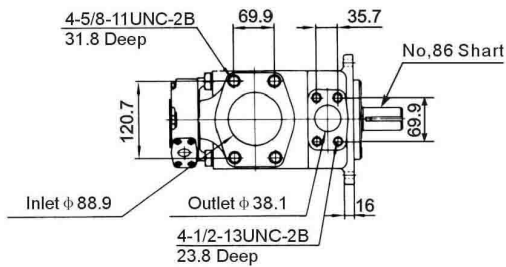

For other shaft dimensions, refer to page 49

4520VQ Foot Mounting

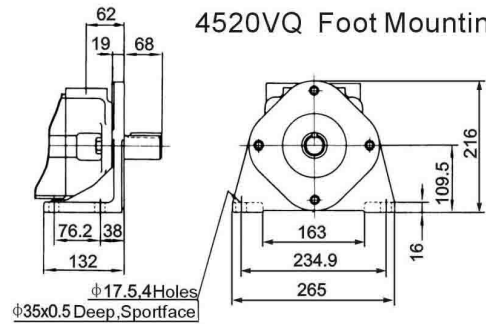

For other dimensions, refer to "Flange Mounting" type.

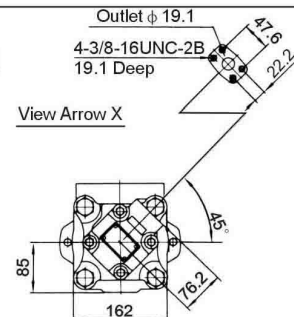
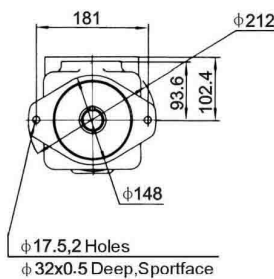

Installation dimensions

4525VQ Flange Mounting

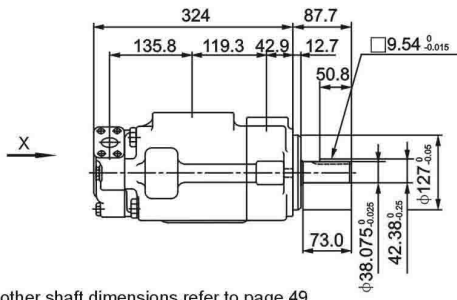
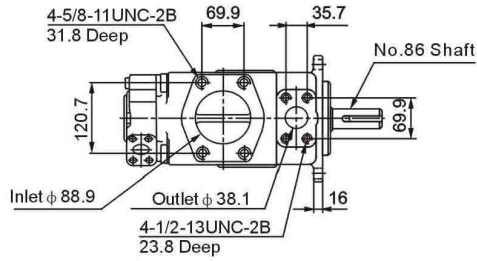

For other shaft dimensions, refer to page 49

4525VQ Foot Mounting

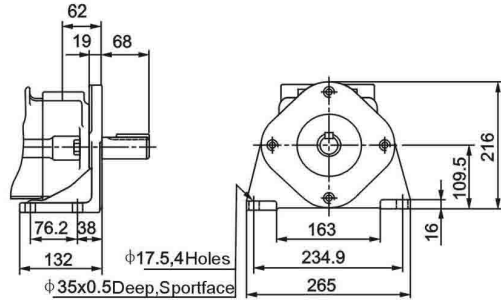

For other dimensions, refer to "Flange Mounting" type.

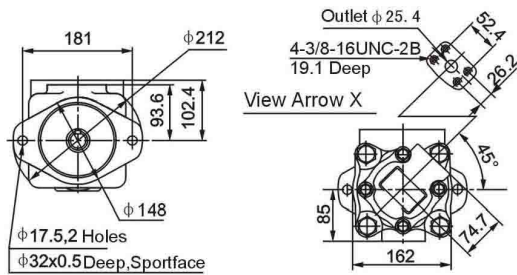

4535VQ Flange Mounting

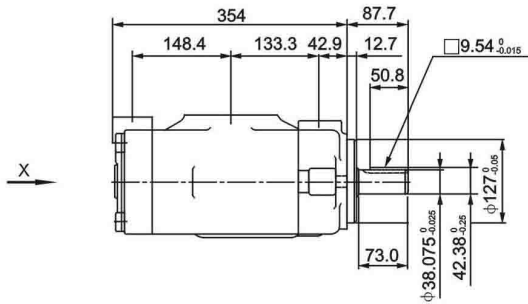
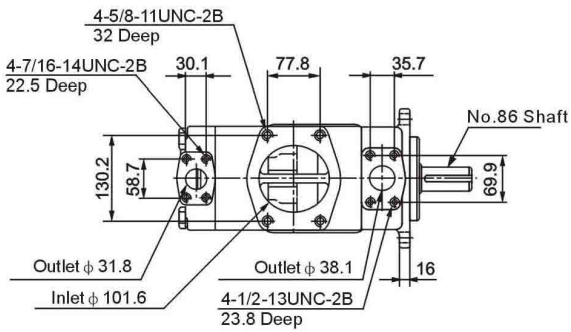

4535VQ Foot Mounting

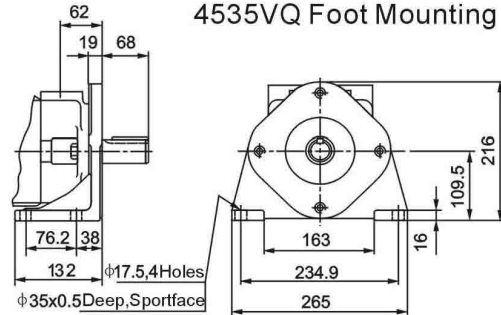

For other dimensions, refer to "Flange Mounting" type.

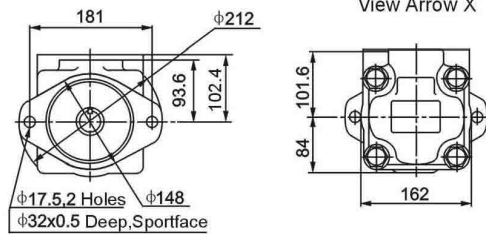

For other shaft dimensions, refer to page 49

VQ Series Cartridge Kits

Model Code

(F3-)	PC-	20VQ	-5	-R	-10
Prefix	Cartridge kits mark	Series	▲ Code	Rotation	Design
Omit-Using antiwear oil water glycol fluid	PC-Single pump cartridge kits Double pump shaft end pump cartridge kits	20VQ	2,3,4,5,6,7,8,9,10, 11,12,14	(Viewed from shaft end of pump) R-Right hand for clockwise L-Left hand for counter clockwise	10
		25VQ	10,12,14,15,17,19, 21		
F3-Phosphated ester fluid	PCT-Double pump cover end pump cartridge kits	35VQ	21,25,30,32,35,38,45		
		45VQ	42,45,50,57,60,66,75		

▲ Rated capacity (USgpm) at 1200 rpm, 0.69 MPa (100 psi).

Installation dimensions

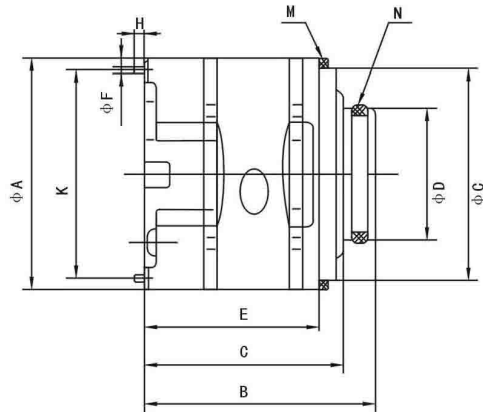

Series	A	B	C	D	E	F	G	H	K	M (Gasket)	N (O-Ring)
20VQ	82.5	81.5	70.1	47	61.5	4.8	76.2	7	73.6	82.76×76.26×3.5	40×3.5
25VQ	96.8	98.8	87	52.2	71.2	4.8	90.5	7	88.19	97×91×3.5	44×3.53
35VQ	114.3	117.7	105	72.2	90.3	6.4	108	7	103.94	114.5×108.5×3.5	63.09×3.53
45VQ	133.35	141.1	129.6	80.2	105.5	6.4	127	11	133.35	133.6×127.6×3.5	71×3.55

Series	Inner spline dentiform parameter of rotor				
	Pitch	Number of teeth	Pressure angle	Major diameter	Minor diameter
20VQ	48/96	30	45°	16.617	15.56
25VQ	48/96	40	45°	21.9	20.86
35VQ	40/80	37	45°	24.38	23.1
45VQ	12/24	14	30°	32.59	27.60